

Item#

Project

Date

Models: PB-330, PB-430



## Models PB-430 & PB-330



Model PB-330



Model PB-430

## Features

- Model PB-330 is a single, digitally controlled brewer. It includes (1) radiant heat, air-insulated, ACS-1 Shuttle®.
- Model PB-430 is a twin, digitally controlled brewer. It includes (2) radiant heat, air-insulated 1.5 gallon (5.7L), ACS-1 Shuttles®.
- The ACS-1 Shuttle® is the classic 1.5 gallons (5.7L) stainless steel, air insulated, radiant heat Shuttle®.
- Programmable Pre-Infusion – Allows the operator complete control over the initial soaking of the grounds independently from Pulse Brewing feature.
- Programmable Energy Saving Feature – Allows the brewer to go into energy conservation mode after three hours of inactivity.
- Improved Operator Feedback – Real-time feedback provides operator with: 1) a brew cycle countdown timer; instant knowledge of when the spray-over will finish. 2) a scrolling dripping message indicating that the brew basket is draining. 3) a scrolling done message indicating that the brew cycle is completely done.
- Programmable Drip Time – Allows operator to control the length of time the brew basket will remain locked after the spray over is completed.
- The following brew variables are programmable through the front display: Water temperature, brew volume, pulse brewing sequence, bypass percentage, low temp/no brew.
- Precise Brew Temperature – The brewer will hold the brew temperature to +/-1°F during the complete brew cycle.
- 3 Brew Volumes – From ½ gallon (1.9L) to 1½ gallons (5.7L). Each volume can be set by 'teach' mode to eliminate trial-&-error set-up.
- Pulse Brewing – Allows the operator to have complete control over the coffee grounds and water contact time. Up to 10 pulses.

# Models & Dimensions



## PB-330 Single, Digitally Controlled Brewer

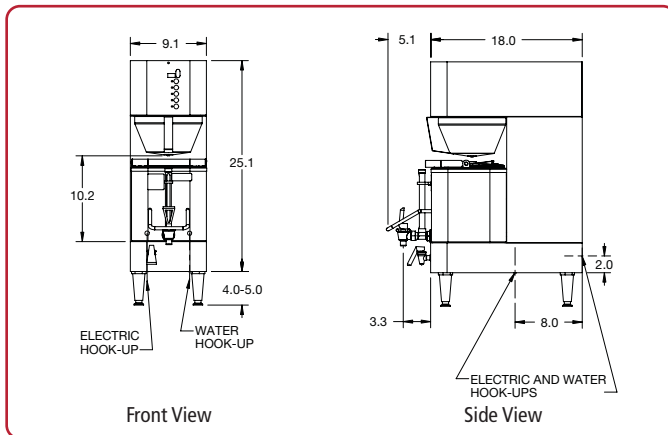

## PB-430 Twin, Digitally Controlled Brewer

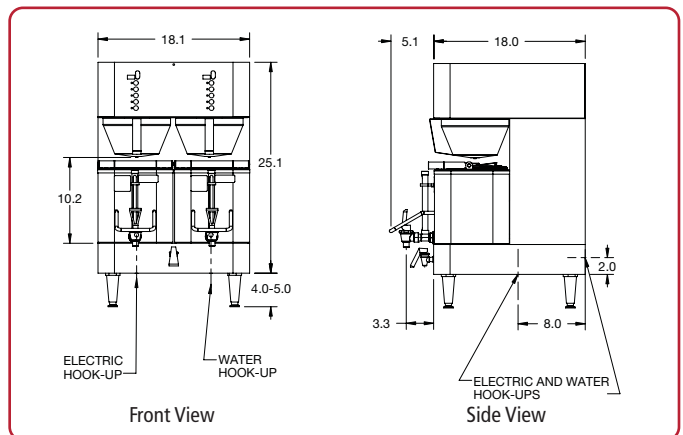

## Specifications

Model	Description	Dimensions (H x W x D)	Ship Dimensions (H x W x D)	Electrical	Ship Weight
PB-330	Single, digitally controlled brewer brews into (1) radiant heat, air insulated, 1.5 gallon CS-LL Shuttle® (included).	25" x 9" x 18" (64 cm x 23 cm x 46 cm)	33" x 11" x 26" (83 cm x 28 cm x 66 cm)	120/240V, 6600W, 28A 120/208V, 5000W, 24A	55 lbs. (25 kg)
PB-430	Twin, digitally controlled brewer brews into (2) radiant heat, air insulated 1.5 gallon CS-LL Shuttles® (included).	25" x 18" x 18" (64 cm x 46 cm x 46 cm)	33" x 27.5" x 22" (83 cm x 69 cm x 55 cm)	120/240V, 6600W, 28A 120/208V, 5000W, 24A	100 lbs. (45 kg)

**Plumbing:** 3/8" (9.5 mm) flare water line at 30 - 80 psi required. **Electrical:** Line cord not included. Export voltage available, see International guide. **Capacity:** 5 oz. (148 ml) cups/hour (140°F Δ T) PB-330 @ 240V = 460, @ 208V = 385. PB-430 @ 240V = 500, @ 208V = 385. Contact Grindmaster-Cecilware™ for more information. Specifications subject to improvement or change without notice.

## Accessories

Model	Description
CS-1	Additional Shuttle® 12 lbs. (5.41 kg).
CW-1	Warmer - 120V, 1 Amp 6 lbs. (2.72 kg).
CW-1H	Warmer with 11" faucet clearance 6 lbs. (2.72 kg).
BB1.5WP	13" x 5" filter paper for BB1.5SS - 500/case.
BB2.0WP	14" x 6" filter paper for BB2.0SS - 500/case.
DP-15	Drip pan for PB-430.
DP-8	Drip pan for PB-330.

## Options

Model	Description
C60K	Higher support frame for 12" (305 mm) faucet clearance PB-430.
C30K	Higher support frame for 12" (305mm) faucet clearance PB-330.
BB2.0SS	Gourmet brew basket.
A418-032	Gourmet spray head.
AOPT-248	3 Heater 15KW (high output) PB-430 only.
AOPT-303	Master power switch.
AOPT-304	Shuttle® lockout switch (PB-330).
AOPT-305	Shuttle® lockout switch (PB-430).



GRINDMASTER-CECILWARE™ 4003 Collins Lane, Louisville, KY 40245 USA

Tel: +1.502.425.4776 / 800.695.4500 (USA & Canada only) • Fax: +1.502.425.4664 • www.grindmaster.com • Email: info@grindmaster.com